

Vehicle transport wagon type 547 Laekk(q)s

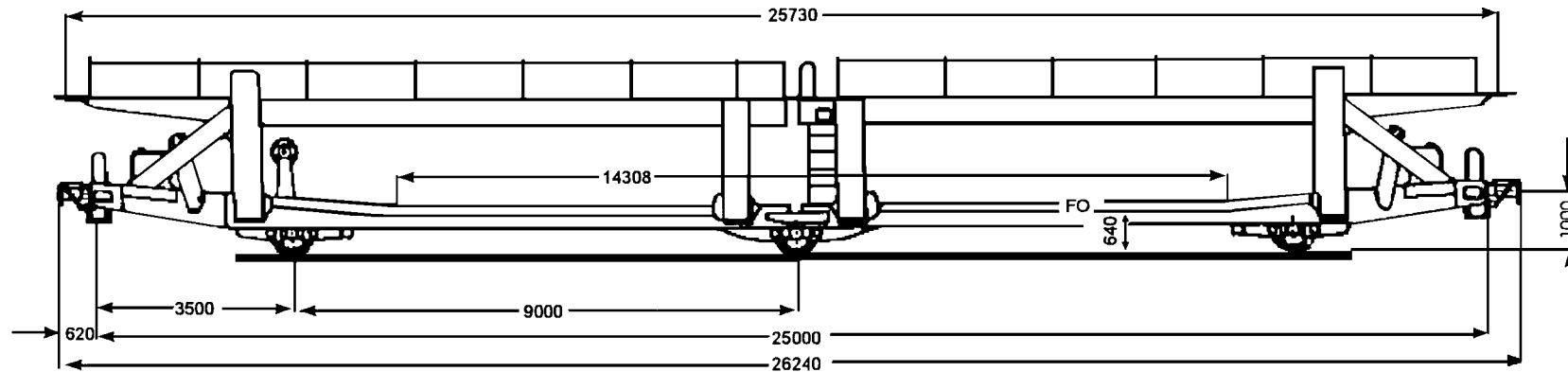

Maximum load per unit

	A	B	C
S	20,0		

Average empty weight

25,5 t

Length over buffers

26.240 mm

Height above rail level

640 mm

Minimum curved track radius

80 m

Mobile wagon components

4 crank handles

Number / type of wheel stoppers

48 hinged wheel stoppers

International usage

RIV

Upper deck completely lowerable

Loading height

see back page

Loading gauge height

see back page

Loading length

25.430 mm

25.730 mm

Loading width

2.990 mm

2.850 mm

Gauge (exterior)

2.050 mm

2.050 mm

Weight of load (max. 20,0 t)

12,0 t

10,0 t

lower deck

upper deck

Vehicle transport wagon type 547 Laekk(q)s

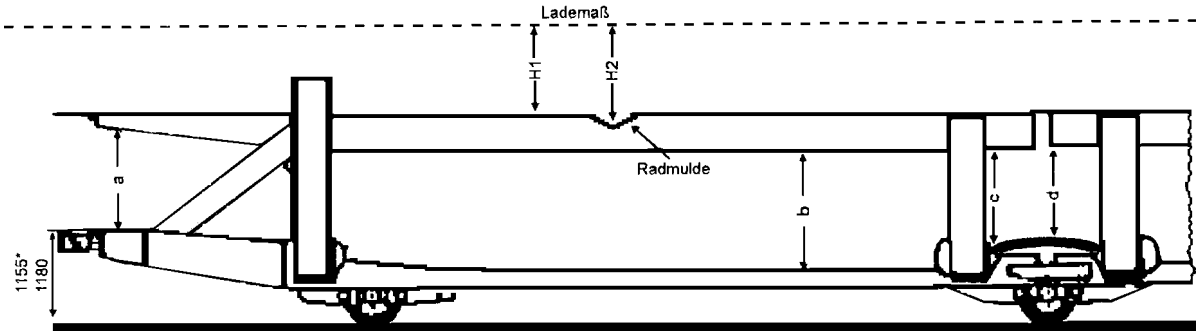

use of brown (smaller) forelock

Upper deck in position	Clearance height of lower deck (mm)				Maximum loading gauge of upper deck (mm) in									
					Germany		France		Italy		Belgium		Switzerland	
	a	b	c	d	H1	H2	H1	H2	H1	H2	H1	H2	H1	H2
1-1	1.245 1.270*	1.785	1.705	1.640	2.195	2.245	1.825	1.875	1.845	1.895	2.145	2.195	2.045	2.095
2-2	1.485 1.510*	2.025	1.945	1.880	1.955	2.005	1.585	1.635	1.605	1.655	1.905	1.955	1.805	1.855
3-3	1.585 1.610*	2.125	2.045	1.980	1.855	1.905	1.485	1.535	1.505	1.555	1.805	1.855	1.705	1.755
completely lowered	-	-	-	-	3.170	3.260	2.800	2.890	2.820	2.910	3.120	3.210	3.020	3.110

* Laekks 547 from wagon-no. 4254 614-x

use of grey (bigger) forelock

Upper deck in position	Clearance height of lower deck (mm)				Maximum loading gauge of upper deck (mm) in									
					Germany		France		Italy		Belgium		Switzerland	
	a	b	c	d	H1	H2	H1	H2	H1	H2	H1	H2	H1	H2
1-1	1.285 1.310*	1.825	1.745	1.680	2.155	2.205	1.785	1.835	1.805	1.855	2.105	2.155	2.005	2.055
2-2	1.525 1.550*	2.065	1.985	1.920	1.915	1.965	1.545	1.595	1.565	1.615	1.865	1.915	1.765	1.815
3-3	1.625 1.650*	2.165	2.085	2.020	1.815	1.865	1.445	1.495	1.465	1.515	1.765	1.815	1.665	1.715
completely lowered	-	-	-	-	3.170	3.260	2.800	2.890	2.820	2.910	3.120	3.210	3.020	3.110

* Laekks 547 from wagon-no. 4254 614-x